

FIT[®]5X

Digital load cell for dynamic weighing

SPECIAL FEATURES

- Accuracy class C3 with OIML R60 test report
- Maximum capacities 5 kg ... 20 kg
- Off-center load compensated (OIML R76)
- Dosing mode
- 4 limit value switches
- Trigger mode (external or level)
- Automatic parameterization for dynamic applications
- PC software or web server visual parameter setup and dynamic analysis
- Designed for daisy-chain topology
- Stainless steel
- Degree of protection IP68/IP69K
- Integral overload protection
- Various options and accessories are available



DIMENSIONS

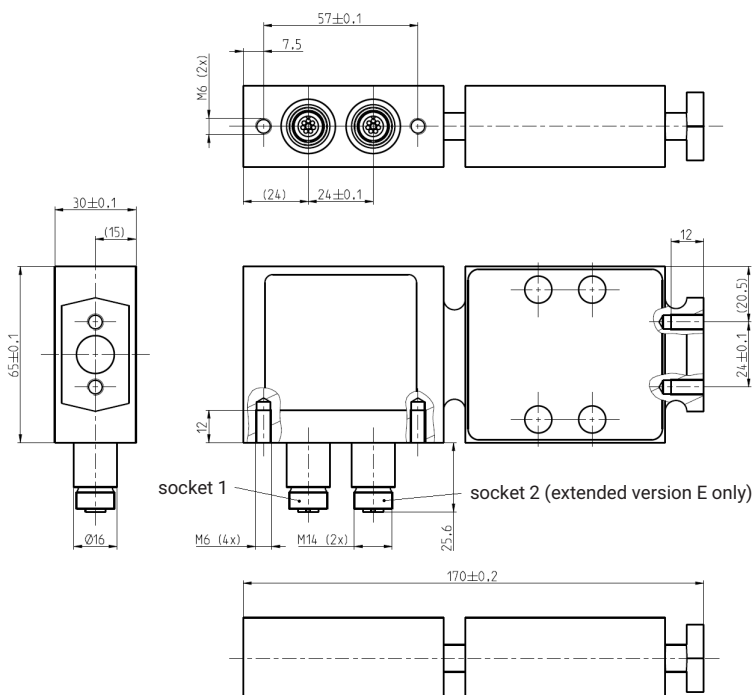

Dimensions in mm (1 mm = 0.03937 inches)

SPECIFICATIONS

General specifications					
Type			FIT5X		
Accuracy class 1)			C3		
Number of load cell verification intervals	n_{LC}		3000		
Fraction	P_{lc}		0.8		
Maximum capacity	E_{max}	kg	5	10	20
Minimum load cell verification interval (standard)	v_{min}	g	0.5	1	2
Temperature coefficient of the zero signal per 10 K (standard) 1)2)	TC_0	% of C_n	±0.0160		
Temperature coefficient of the zero signal per 10 K (option) 1)2)	TC_0		±0.0064	±0.0080	
Maximum platform size		mm	400 x 400		
Nominal (rated) sensitivity	C_n	digit	1000000		
Zero signal			0 ±100000		
Temperature coefficient of the sensitivity per 10 K in the temperature range 4) +20 ... +40°C -10 ... +20°C	TC_S	% of C_n	±0.0218		
Non-linearity 4)			d_{lin}	±0.0150	
Relative reversibility error 4)	d_{hy}		±0.0166		
Minimum dead load output return	MDLOR		±0.0166		
Off-center load error 3)			±0.0233		
Nominal (rated) ambient temperature range	B_T	°C	-10 ... +40		
Operating temperature range	B_{tu}		-10 ... +50		
Storage temperature range	B_{tl}		-25 ... +70		
Limit load at 20 mm eccentricity	E_L	% of E_{max}	1000		
Service load at max. 120 mm eccentricity			150		
Relative vibrational stress at max. 50 mm eccentricity	F_{srel}		70		
Nominal (rated) displacement 5)	s_{nom}	mm	<0.2		
Weight, approx.	m	kg	1.6		
Degree of protection per DIN EN 60529 (IEC 529)			IP68 (test condition 1 m water column / 100 h); IP69K (not for Ethernet version) (water at high pressure, steam cleaner) 6)		
Voltage supply Operating voltage (DC) Power consumption Start-up current	U_B	V	+10 ... +30		
		W	≤2		
		A	<0.2		
Measuring body material			Stainless steel 1.4545 7)		
Measurement signal resolution		bit	24		
Data rate		1/s	4 ... 1200		
Digital filter bandwidth		Hz	0 ... 120		
RS-485 interface baud rates		baud	1200/2400/4800/9600/19200/38400/57600/115200		
Maximum number of bus nodes			90		
CANopen interface (CANopen/DeviceNet) Baud rate Maximum cable length		baud m	Standard CiA DS301 10000 ... 1000000 ≤5000 (10 kBaud) ... ≤100 (500 kBaud) ... ≤25 (1 MBaud)		

General specifications		
DeviceNet		Release 2.0 DVA
Baud rate	baud	125000 ... 500000
Maximum cable length	m	≤5000 (10 kBaud) ... ≤100 (500 kBaud)
Diagnostics bus RS-485 2-wire (extended version E)		
Baud rate	baud	38400
Maximum cable length	m	500
Asynchronous interface RS-485 4-wire (socket 1)		
Baud rate	baud	1200/2400/4800/9600/19200/38400/57600/115200
Maximum cable length	m	500
Trigger input (socket 1)		
Input voltage	V	0 ... +12
Low level	V	<1
High level	V	>4
Input resistance	kΩ	70
Control inputs (extended version E, socket 2) ⁸⁾		
Input voltage	V	0 ... +30
Low level	V	<6
High level	V	>10
Input resistance	kΩ	9
Control outputs (extended version E, socket 2) ⁸⁾		
External supply voltage	V	+11 ... +30
Max. current per output	A	<0.5
Max. total current of all outputs	A	<1

1) As per OIML R60, with $P_{LC} = 0.8$.

2) "Test Certificate" extension in preparation.

3) As per OIML R76.

4) The values for non-linearity (d_{lin}), relative reversibility error (d_{hy}) and temperature coefficient of sensitivity (TC_S) are recommended values. The sum of these values is within the cumulated error limits according to OIML R60.

5) Loading with F_{max} and center of gravity in center of platform.

6) Based on DIN 40050, Part 9 specifications, for road vehicles.

7) As per EN 10088-1.

8) The signals apply to GND of socket 1.

Ethernet version specifications		
Voltage supply		
Operating voltage (DC)	V	typically: 24; min: 15; max: 30
Power consumption	W	≤3
Start-up current	mA	60 ±15 (typ.)
Measurement signal resolution	bit	24
Sample rate	1/2	2,000
Power supply cable length		≤30
Interface cable length	m	≤100
Overvoltage protection	V	up to 35
Reverse polarity protection	V	up to ±35
Switch-on time before initial data acquisition	s	<1
Digital filters, up to 5 cascable	Hz	IIR low pass: 0.1 ... 30 FIR low pass: 3 ... 30 Moving average: 1 ... 100 Comb filter: 1 ... 100
Weighing functions		Checkweigher with pre- and post-trigger, trigger either level controlled or via external photoelectric sensor; Filling and dosing for filling or emptying, with coarse and fine flow control as well as automatic optimization of target weight, FTT analysis (computational and graphical) to identify and filter or reduce spurious frequencies

Ethernet version specifications		
Peak-value memory Number Function Sources Response time	ms	3 Minimum, maximum, peak-to-peak mV/V (raw value), gross measured value, net measured value 0.5
Oscillation according to Class III (following DIN IEC 68 part 2 to 6) Frequency range Duration Acceleration	Hz min m/s ²	5 ... 65 30 per direction 50
Shock according to Class III (following DIN IEC 68 part 2 to 27) Number Duration Acceleration	ms m/s ²	10 in each of the six possible directions 6 350
EMC standards		IEC 61326-1: 2012; EN 61326-1: 2013.07; EN 45501: 2015-02
Operation		10 formulations/parameter sets with all device settings
Configuration		Via integrated web server (via TCP/IP) or via fieldbus
Firmware update		Via integrated web server with multilingual operator dialogs

ELECTRICAL CONNECTION

M12 female 8-pin device sockets 1 and 2

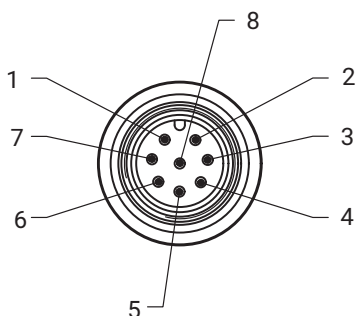

M12 male 12-pin device socket

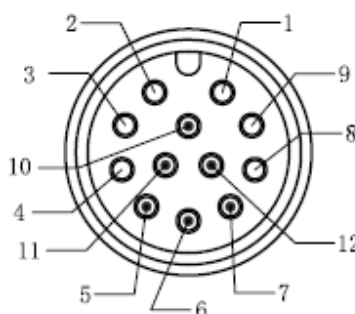

FIT5X pin assignment - type S, RS-485, CANopen, DeviceNet version

Device socket 1				
Pin	RS-485	CANopen/DeviceNet	Wiring code for 1-KAB165 ¹⁾	Wiring code for 1-KAB173 ¹⁾
1	GND	GND	White	White
2	-	-	Brown	Brown
3	RA	CAN High IN	Green	Green
4	Trigger input ²⁾	Trigger input ²⁾	Yellow	Yellow
5	RB	CAN Low IN	Gray	Gray
6	TB	CAN Low OUT	Pink	Black
7	TA	CAN High OUT	Blue	Blue
8	U _{B1}	U _{B1}	Red	Red

¹⁾ For digital load cells, HBK recommends two cable types, 1-KAB165 or 1-KAB173, depending on the application. Detailed information about these cables is available in data sheet 'Cables and plugs', which can be found in the load cell accessories section on our website <https://www.hbkworld.com/en/products/transducers/load-cells/accessories>

²⁾ The trigger input is referenced to the GND of pin 1.

FIT5X pin assignment - type E, RS-485, CANopen, DeviceNet version

Device socket 1 – digital communication				
Pin	RS-485	CANopen/DeviceNet	Wiring code for 1-KAB165 ¹⁾	Wiring code for 1-KAB173 ¹⁾
1	GND	GND	White	White
2	Diagnosis RbTb	Diagnosis RbTb	Brown	Brown
3	RA	CAN High IN	Green	Green
4	Diagnosis RaTa	Diagnosis RaTa	Yellow	Yellow
5	RB	CAN Low IN	Gray	Gray
6	TB	CAN Low OUT	Pink	Black
7	TA	CAN High OUT	Blue	Blue
8	U _{B1}	U _{B1}	Red	Red

Device socket 2 – inputs and outputs			
Pin		Wiring code for 1-KAB165 ¹⁾	Wiring code for 1-KAB173 ¹⁾
1	-	White	White
2	IN2	Brown	Brown
3	OUT2	Green	Green
4	IN1	Yellow	Yellow
5	OUT4	Gray	Gray
6	OUT3	Pink	Black
7	OUT1	Blue	Blue
8	U _{B2} ²⁾	Red	Red

1) For digital load cells, HBK recommends two cable types, 1-KAB165 or 1-KAB173, depending on the application. Detailed information about these cables is available in data sheet 'Cables and plugs', which can be found in the load cell accessories section on our website <https://www.hbkworld.com/en/products/transducers/load-cells/accessories>





2) For U_{B2}, choose either the same voltage source as for U_{B1}, or a separate voltage source. In both cases, the signals are referenced to the GND with which pin 1 of socket 1 is connected. If a separate voltage source is chosen for the inputs and outputs, this must be connected with the common GND of pin 1.

FIT5X pin assignment - Ethernet version



Device socket 1 - power, inputs and outputs		
Pin		Wiring code for KAB194 ¹⁾
1	Power supply IN	Brown
2	Power supply GND	Blue
3	Power supply GND isolated for DIO	White
4	Power supply 24V isolated for DIO	Green
5	DIO1	Pink
6	DIO2	Yellow
7	DIO3	Black
8	DIO4	Gray
9	DO5	Red
10	DO6	Purple
11	-	Gray/Pink
12	-	Red/Blue

Device socket 2 - Ethernet communication			
Pin	Ethernet	Ethernet ports splitter cable KAB442	Ethernet communication cable
1	TX+ port 1	Use 1-KAB442-1 to split the 8-pin M12 fusion port to two Ethernet ports, 4-pin M12 D-coded, one male, one female, daisy chain capable.	1-KAB2129-5-1, male M12 on RJ45, 4-pin, D-coded, 5m long. 1-KAB2145-5-1, female M12 on RJ45, 4-pin, D-coded, 5m long.
2	RX+ port 1		
3	TX- port 1		
4	RX- port 1		
5	TX+ port 2		
6	RX+ port 2		
7	TX- port 2		
8	RX- port 2		



LED STATUS

LED pos.	Meaning	
P2 OUT: Link/Act	Ethernet Port 2 OUT Link, Active	 P2 OUT: Link / Act
P1 IN: Link/Act	Ethernet Port 1 IN Link, Active	 P1 IN: Link / Act
ERR BF NS	ERR(Error) for EtherCAT or Modbus, BF(Bus Failure) for PROFINET, NS(Network Status) for EtherNet/IP.	 ERR BF NS
RUN SF MS	RUN(Run) for EtherCAT or Modbus, SF(System Failure) for PROFINET, MS(Module Status) for EtherNet/IP.	 RUN SF MS
System	System status	 System



System LED



LED	Device Status	Meaning
	On	In operation. The device is working without error.
	On	Overload / Underload.
	On	Device error, check supply voltage and settings.

Link/Act LED







LED	Device Status	Meaning
	On	The device is linked to the Ethernet.
	Flickering	The device sends/receives Ethernet frames.
	Off	The device has no link to the Ethernet.







PROFINET LED, BF and SF

BF LED	Device Status	Meaning
	Off	No error.
	Flashing (2 Hz)	No data exchange.
	On	Error: no configuration, slow or no physical connection.





SF LED	Device Status	Meaning
	Off	No error.
	Flashing (1 Hz 3 sec.)	A DCP signal service is triggered via the bus.
	On	Watchdog timeout: There is a system error or a channel, generic or extended diagnostic.





EtherNet/IP LED, MS and NS

MS LED	Device Status	Meaning
	On	Device operational: The device is operating correctly.
	Flashing (1 Hz)	Standby: The device has not been configured.
	Flashing fast green/red/green	Self-test: The device performs a self-test after power-on.
	Flashing (1 Hz)	Major recoverable fault.
	On	Major unrecoverable fault.
	Off	No power: The device is powered off.





NS LED	Device Status	Meaning
	On	Connected.
	Flashing (1 Hz)	No connections.
	Flashing fast green/red/off	Self-test: The device performs a self-test after power-on.
	Flashing (1 Hz)	Connection timeout.
	On	Duplicate IP address.
	Off	Not powered, no IP address.



EtherCAT LED, RUN and ERR

RUN LED	Device Status	Meaning
	On	The device is in the OPERATIONAL state.
	Single flash	The device is in SAFE-OPERATIONAL state.
	Flashing (2.5 Hz)	The device is in PRE-OPERATIONAL state.
	Off	The device is in INIT state.

ERR LED	Device Status	Meaning
	Blinking (2.5 Hz)	Invalid configuration: General Configuration Error Possible reason: State change commanded by master is impossible due to register or object settings.
	Single flash	Local error: Slave device application has changed the EtherCAT state autonomously. Possible reason 1: A host watchdog timeout has occurred. Possible reason 2: Synchronization Error, device enters Safe-Operational automatically.
	Double flash	Application watchdog timeout: An application watchdog timeout has occurred. Possible reason: Sync Manager Watchdog timeout.
	Off	No error: The EtherCAT communication of the device is in working condition.

Modbus LED, RUN and ERR

RUN LED	Device Status	Meaning
	On	Connected: device has communication. At least one TCP connection is established.
	Flashing (1 Hz)	Ready, not configured yet: device is ready but not yet configured.
	Flashing (5 Hz)	Waiting for Communication: device is configured.
	Off	Not Ready: device is not ready.

ERR LED	Device Status	Meaning
	On	Communication error active
	Flashing (2 Hz, 25 % on)	System error
	Off	No communication error

PRODUCT NUMBERS (OVERVIEW)

Type	1-FIT5X	
Accuracy class	C3 (OIML)	
Maximum capacity	Ordering number	Remarks
5 kg	1-FIT5XEB3/5KG-1	2 sockets, RS-485, 2 inputs & 4 outputs, diagnosis channel
5 kg	1-FIT5XEC3/5KG-1	2 sockets, CANopen, 2 inputs & 4 outputs, diagnosis channel
5 kg	1-FIT5XED3/5KG-1	2 sockets, DeviceNet, 2 inputs & 4 outputs, diagnosis channel
5 kg	1-FIT5XEE3/5KG-1	2 sockets, PROFINET or EtherNet/IP or EtherCAT or Modbus switchable, 2 outputs & 4 inputs/outputs configurable
10 kg	1-FIT5XEB3/10KG-1	2 sockets, RS-485, 2 inputs & 4 outputs, diagnosis channel
10 kg	1-FIT5XEC3/10KG-1	2 sockets, CANopen, 2 inputs & 4 outputs, diagnosis channel
10 kg	1-FIT5XED3/10KG-1	2 sockets, DeviceNet, 2 inputs & 4 outputs, diagnosis channel
10 kg	1-FIT5XEE3/10KG-1	2 sockets, PROFINET or EtherNet/IP or EtherCAT or Modbus switchable, 2 outputs & 4 inputs/outputs configurable
20 kg	1-FIT5XEB3/20KG-1	2 sockets, RS-485, 2 inputs & 4 outputs, diagnosis channel
20 kg	1-FIT5XEC3/20KG-1	2 sockets, CANopen, 2 inputs & 4 outputs, diagnosis channel
20 kg	1-FIT5XED3/20KG-1	2 sockets, DeviceNet, 2 inputs & 4 outputs, diagnosis channel
20 kg	1-FIT5XEE3/20KG-1	2 sockets, PROFINET or EtherNet/IP or EtherCAT or Modbus switchable, 2 outputs & 4 inputs/outputs configurable

ACCESSORIES

Suitable connection cables

Type	Ordering number
Connection cable with M12 M plug, 8-pin, TPU IP67, PUR cable sheath, 3 m long	1-KAB165-3
Connection cable with M12 M plug, 8-pin, TPU IP67, PUR cable sheath, 6 m long	1-KAB165-6
Connection cable with M12 M plug, 8-pin, TPU IP67, PUR cable sheath, 12 m long	1-KAB165-12
Connection cable with M12 M plug, 8-pin, stainless steel IP68/IP69K, TPE cable sheath, 3 m long	1-KAB173-3-1
Connection cable with M12 M plug, 8-pin, stainless steel IP68/IP69K, TPE cable sheath, 6 m long	1-KAB173-6-1
Ethernet ports splitter cable with M12 Male plug, 8-pin, split to two 4-pin M12 plugs, D-coded, one male, one female	1-KAB442-1
Ethernet communication cable, CAT5, M12 Male plug on RJ45, 4-pin, D-coded, 5 m long	1-KAB2129-5-1
Ethernet communication cable, CAT5, M12 Female plug on RJ45, 4-pin, D-coded, 5 m long	1-KAB2145-5-1
Connection cable with M12 Female plug, 12-pin, stainless steel IP68/IP69K, TPE, 5 m long	1-KAB194-5-1

Additional connection cable data can be found in the HBK cables and plugs data sheet (B03644).

K-FIT5X..., OPTIONAL VERSIONS

K-FIT5X		
1	Code	Option 1: Mechanical design
	N	Standard
2	Code	Option 2: Accuracy class
	C3	C3
3	Code	Option 3: Nominal load
	5	5 kg
	10	10 kg
4	Code	Option 4: Explosion protection
	N	No ATEX
5	Code	Option 5: Electrical connection
	N	Socket
6	Code	Option 6: Miscellaneous
	VA	Y = 10000
7	Code	Option 7: Communication protocol
	B	RS-485
	C	CANopen
	D	DeviceNet
	E	PROFINET or EtherNet/IP or EtherCAT or Modbus switchable
8	Code	Option 8: Interface
	S	1 socket, with trigger [only with option 7 = B/C/D]
	E	2 sockets

K-FIT5X - N - C3 - - N - N - VA - -

1 2 3 4 5 6 7 8

Hottinger Brüel & Kjaer GmbH

Im Tiefen See 45 · 64293 Darmstadt · Germany
 Tel. +49 6151 803-0 · Fax +49 6151 803-9100
 www.hbkworld.com · info@hbkworl.com

Subject to modifications. All product descriptions are for general information only. They are not to be understood as a guarantee of quality or durability.