

DATA SHEET

U9C Force Transducer

SPECIAL FEATURES

- Tensile/compressive force transducer
- HBK accuracy class 0.2
- Nominal (rated) forces 50 N - 50 kN
- Available on request as a measurement chain with permanently connected inline amplifier.
Output signals: mA, V or IO-Link
- Non-rusting, protection class IP67
- Configurable with different cable lengths, plug assembly on request
- High rigidity, particularly suited for dynamic measurement tasks
- Cable suitable for drag chains, resistant to most oils and operating materials.



TABLE OF CONTENTS

Principle of the U9C force transducer	2
Dimensions	3
Dimensions U9C with nominal (rated) forces 50 N, 100 N and 200 N	3
Dimensions U9C with nominal (rated) forces 0.5 kN to 50 kN	3
Dimensions inline amplifier VA1, VA2, VAIO	4
Dimensions Knuckle eyes (to be ordered separately)	4
U9C with one or two knuckle eyes	5
Electrical connection	6
Wiring diagram of U9C without inline amplifier	6
Pin assignment of inline amplifier VA1, VA2	6
Pin assignment of VAIO inline amplifier	6
Specifications	7
Specifications U9C	7
Specifications Inline amplifier VA1, VA2	8
Specifications VAIO inline amplifier	9
Versions and ordering numbers	11
Accessories	12

PRINCIPLE OF THE U9C FORCE TRANSDUCER

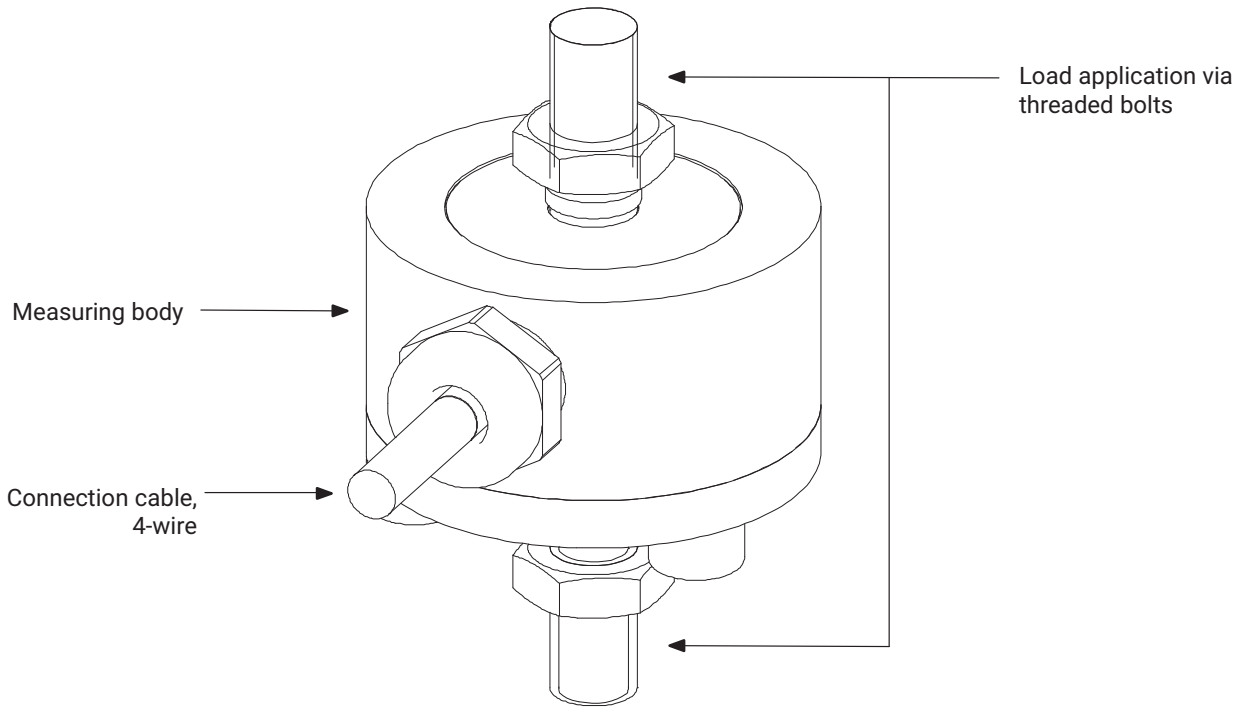

DIMENSIONS

Dimensions U9C with nominal (rated) forces 50 N, 100 N and 200 N

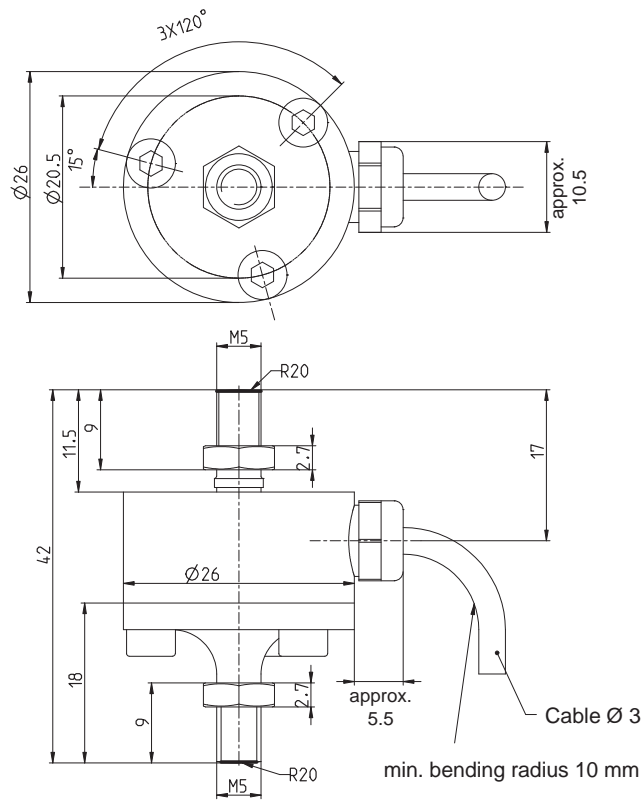

Dimensions U9C with nominal (rated) forces 0.5 kN to 50 kN

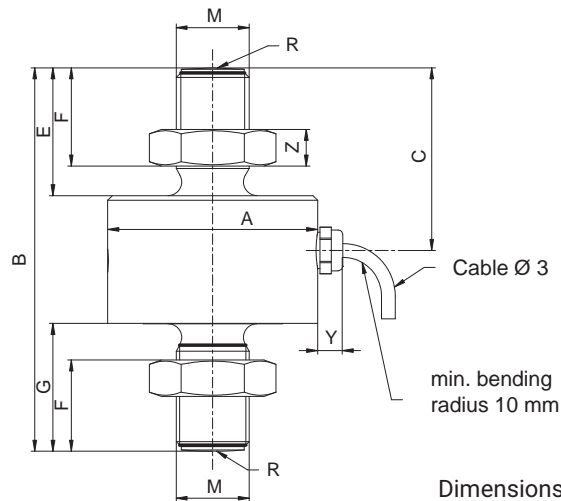

Dimensions in mm (1 mm = 0.03937 inches)

Nominal (rated) force of the U9C	A-0.1	B	C	E	F	G	M	R	Y	Z
	mm									
0.5 kN to 1 kN	26	44.5	20.5	13	9.5	13.5	M5	20	approx. 5.5	2.7
2 kN to 20 kN	26	60	28.5	21	16	21	M10	40	approx. 5.5	5
50 kN	46	84	40	28	21.5	28	M16 x 1.5	80	approx. 5.5	8

Dimensions inline amplifier VA1, VA2, VAIO

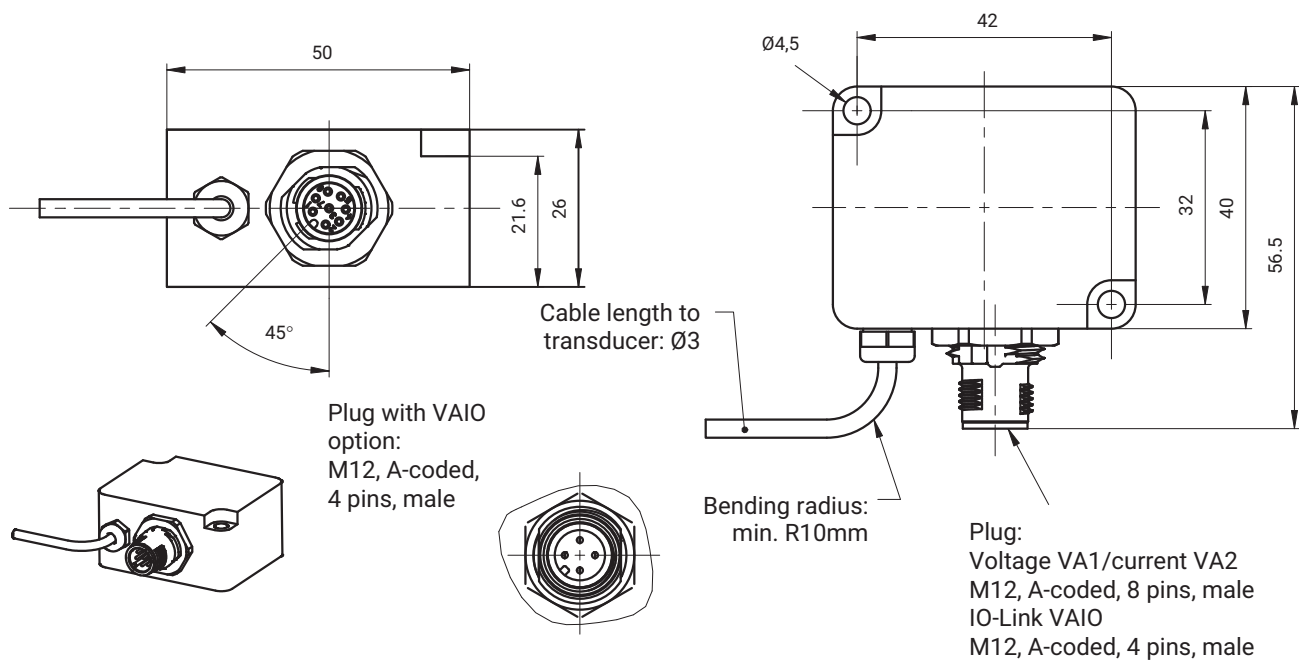

Dimensions Knuckle eyes (to be ordered separately)

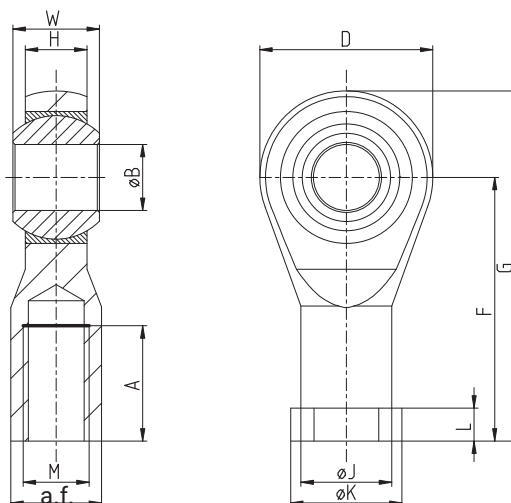

Nominal (rated) forces	Ordering number	A	B ^{H7}	D	F	G	H	J	K	L	M	a.f.	W
		mm											
50 N to 1 kN	1-Z8/100kg/ZGW	10	5	18	27	36	6	9	11	4	M5	9	8
2 kN to 20 kN	1-U9/20KN/ZGWR	20	10	28	43	57	10.5	15	19	6.5	M10	17	14
50 kN	1-U9a/50kN/ZGW	28	16	42	64	85	15	22	27	8	M16 x 1.5	22	21

U9C with one or two knuckle eyes

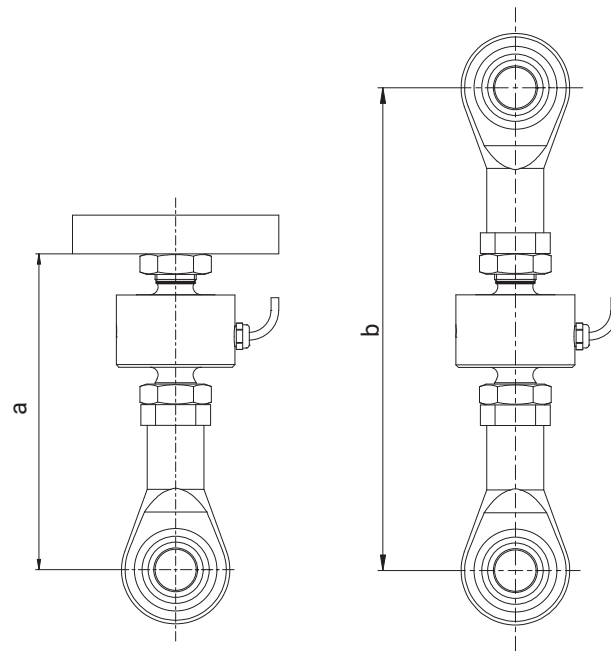

Nominal (rated) force	a_{min}	a_{max}	b_{min}	b_{max}
	mm			
50 - 20 N	55	59	82	86
0.5 - 1 kN	56	61	83	88
2 - 20 kN	79	82	122	125
50 kN	116	116	180	180

Mounting dimensions of the U9C when using knuckle eyes

ELECTRICAL CONNECTION

Wiring diagram of U9C without inline amplifier

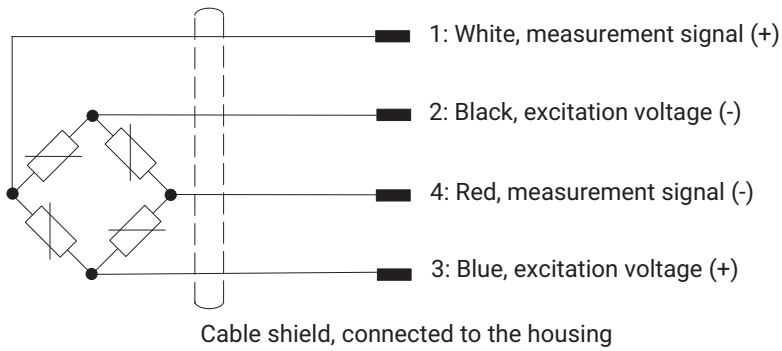

Pin assignment of inline amplifier VA1, VA2

Pin	Version VA 1 (voltage output)	Version VA 2 (current output)	KAB168 connection cable wire assignment
1	Supply voltage 0 V (GND)		white
2	Not in use		brown
3	Control input zero setting		green
4	Not in use		yellow
5	Output signal 0 ... 10 V	Output signal 4 ... 20 mA	gray
6	Output signal 0 V	Not in use	pink
7	Not in use		blue
8	Voltage supply -19 ... +30 V		red

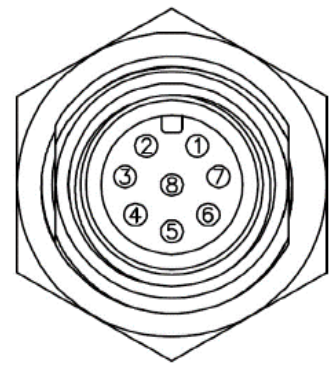

Pin assignment of VAIO inline amplifier

PIN	U9/C9 plug assignment
1	Supply voltage +
2	Digital output (DI/DO pin function)
3	Supply voltage -, reference potential
4	IO-Link data (C/Q), switchover to the digital output (SIO mode) possible

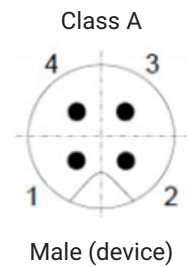

SPECIFICATIONS

Specifications U9C

Nominal (rated) force	F _{nom}	N	50	100	200							
		kN				0.5	1	2	5	10	20	50
Accuracy												
HBK accuracy class			0.2									
Relative reproducibility and repeatability errors without rotation	b _{rg}	%	< 0.2									
Relative reversibility error	v _{0.5}	%	< 0.2									
Non-linearity	d _{lin}	%	< 0.2									
Relative creep (30 min)	d _{cr,F}	%	< 0.2				< 0.1					
Effect of the bending moment at 10% F _{nom} * 10 mm (typical)	d _{Mb}	%	0.055	0.045	2.35					2.45	0.5	
Effect of temperature on sensitivity												
in the nominal (rated) temperature range	TK _C	% / 10 K	0.2									
in the operating temperature range	TK _C	% / 10 K	< 0.5									
Effect of temperature on the zero signal												
in the nominal (rated) temperature range	TK ₀	% / 10 K	< 0.2									
in the operating temperature range	TK ₀	% / 10 K	< 0.50									
Electrical characteristics												
Nominal (rated) sensitivity	C _{nom}	mV/V	1									
Tolerance range of zero signal	d _{s,0}	mV/V	± 0.2									
Sensitivity error	d _c	%	< ± 1 tensile , < ± 2 compressive									
Tensile/compressive sensitivity variation	d _{zd}	%	< 2									
Input resistance	R _i	Ω	250 - 400				300 - 450					
Output resistance	R _o	Ω	200 - 400				145 - 450					
Insulation resistance	R _{iso}	Ω	> 1*10 ⁹									
Operating range of the excitation voltage	B _{u,gt}	V	0.5 - 12									
Reference excitation voltage	U _{ref}	V	5									
Connection			4-wire circuit									
Temperature												
Reference temperature	t _{ref}	°C	23									
Nominal (rated) temperature range	B _{t,nom}	°C	-10 to +70									
Operating temperature range	B _{t,g}	°C	-30 to +85									
Storage temperature range	B _{t,S}	°C	-30 to +85									
Characteristic mechanical quantities												
Max. operating force	F _G	% of F _{nom}	200				150					
Limit force	F _L		> 200				> 150					
Breaking force	F _B		> 400									
Limit torque	M _G	Nm	1.7	3.4	2.5	3.7	4.5	28	23	11	11	35
Limit bending moment when loading with nominal (rated) force	M _{b,zul}	Nm	0.17	0.7	1.5	3.7	3.8	10.2	14.4	8.2	8.6	28.5
Static lateral limit force when loading with nominal (rated) force ²⁾	F _q	% of F _{nom}	100				50	100	50	18	6	8
Nominal (rated) displacement	s	mm	0.008			0.018			0.03	0.05	0.09	0.14

Nominal (rated) force	F _{nom}	N	50	100	200							
		kN				0.5	1	2	5	10	20	50
Fundamental resonance frequency	f _G	kHz	6.5	9.1	12.6	15.3	15.9	13.2	14.5	14.6	14.6	7.2
Relative oscillation width	F _{rb}	% of F _{nom}	70			80					70	
Maximum impact load to ICE 60068-2-6												
Number								1,000				
Duration		ms						3				
Acceleration		m/s ²						1,000				
Vibrational stress to IEC 60068-2-27												
Frequency range		Hz						5 ... 65				
Duration		min						30				
Acceleration		m/s ²						150				
General information												
Degree of protection per EN 60529 ¹⁾								IP67				
Spring element material								Steel				
Potting material								Silicone				
Cables								Four-wire circuit, PUR insulation				
Cable length		m						1.5; 3; 5; 6; 7; 12				
Weight		g	75			100				400		

1) 1 m water column; 0.5 h

2) Pure lateral force without bending moment

Specifications Inline amplifier VA1, VA2

Module type		VA1	VA2
Accuracy			
HBK accuracy class	%	0.15	
Relative linearity error	%	0.01	
Effect of temperature on amplification	%	0.10	
Effect of temperature on zero point	%	0.15	
Rated electrical output			
Output signal		0... 10 V	4 ... 20 mA
Nominal (rated) output		10 V	16 mA
Rated output tolerance		± 0.1 V	± 0.16 mA
Zero signal		5 V	12 mA
Range of output signal		-0.3... 11 V	3 ... 21 mA
Cut-off frequency (-3 dB)	kHz	2	
Supply voltage	V	19 ... 30	
Nominal (rated) voltage	V	24	
Maximum current consumption	mA	15	30
Temperature			
Nominal (rated) temperature range	°C	-10...+50	
Operating temperature range	°C	-20...+60	
Storage temperature range	°C	-25...+85	
Reference temperature	°C	23	
Maximum impact load to ICE 60068-2-6			
Number		1,000	
Duration	ms	3	

Module type		VA1	VA2
Acceleration	m/s ²	1,000	
Vibrational stress to IEC 60068-2-27			
Frequency range	Hz	5 ... 65	
Duration	min	30	
Acceleration	m/s ²	150	
General information			
Housing material		Aluminum	
Weight without cable	g	125	
Maximum cable length for supply voltage/output signal	m	30	
Degree of protection per EN 60529		IP67	

Specifications VAIO inline amplifier

Module type	VAIO	
Accuracy		
HBK accuracy class		0.01
Effect of temperature on amplification	%/10K	0.01
Effect of temperature on zero point	%/10K	0.01
Rated electrical output		
Output signal; interface		COM3, to IO-Link standard, class A
Min. cycle (max. output rate)	ms	0.9
Sample rate (internal)	S/s	40000
Cut-off frequency (-3 dB)	kHz	4
Reference supply voltage	V	24
Supply voltage range	V	19 - 30
Max. power consumption	mW	3200
Noise	ppm of nominal force	With Bessel filter 1 Hz: 25 With Bessel filter 10 Hz: 63 With Bessel filter 100 Hz: 195 With Bessel filter 200 Hz: 275 Without filter: 3020
Filter		
Low-pass filter		Freely adjustable cut-off frequency, Bessel or Butterworth characteristic, 6th order
Device functions		
Limit value switches		2 limit value switches. Invertible, freely adjustable hysteresis. Output via process data or digital output
Digital IO		According to IO-Link Smart Sensor Profile, 1 permanently available digital output, 1 output can be set to data output, then no measurement possible
Lag indicator function		Yes
Peak value memory		Yes
Peak-to-peak memory		Yes
Warning functions		Warning on exceeding nominal (rated) force/maximum operating force; nominal (rated) temperature/maximum operating force
Temperature		
Nominal temperature range	°C	-10 ... +50
Operating temperature range	°C	-10 ... +60
Storage temperature range	°C	-25... +85
Reference temperature	°C	23

Module type		VAIO
Maximum impact load to IEC 60068-2-6		
Number		1000
Duration	ms	3
Acceleration	m/s ²	1000
Maximum vibrational stress to IEC 60068-2-27		
Frequency range	Hz	5 ... 65
Duration	min	30
Acceleration	m/s ²	150

VERSIONS AND ORDERING NUMBERS

Code	Measuring range	Ordering number
050N	50 N	1-U9C/50N
100N	100 N	1-U9C/100N
200N	200 N	1-U9C/200N
00K5	0.5 kN	1-U9C/0.5KN
01K0	1 kN	1-U9C/1KN
02K0	2 kN	1-U9C/2KN
05K0	5 kN	1-U9C/5KN
10K0	10 kN	1-U9C/10KN
20K0	20 kN	1-U9C/20KN
50K0	50 kN	1-U9C/50KN

The ordering numbers shown in gray are preferred types, they can be delivered rapidly.

All preferred types with 1.5 m cable, open ends, without TEDS and without firmware.

The order no. for the preferred types is 1-U9C...

The order no. for customer-specific designs is K-U9C-...

The ordering number example **K-U9C-05K0-03M0-VAIO-S-IO02** shown below is a: U9C, nominal force 5 kN with 3 m cable, inline amplifier with IO-Link output, firmware version 2.0.0

Nominal (rated) force	Cable length	Electrical connection	Transducer identification	Firmware
50 N 050N	1.5 m 01M5	Free ends Y	With TEDS chip T	No firmware N
100 N 100N	3 m 03M0	15-pin Sub-D connector F	Without TEDS chip S	Version 1.2.6 IO01
200 N 200N	5 m 05M0	Male connector MS3106PEMV N		Version 2.0.0 IO02
0,5 kN 00K5	6 m 06M0	15-pin Sub-HD connector Q		Version 2.0.8 IO03
1 kN 01K0	7 m 07M0	8-pin M12 connector M		Version 2.0.10 IO04
2 kN 02K0	12 m 12M0	With inline amplifier 0 .. 10 V VA1		Version 2.0.12 IO05
5 kN 05K0		With inline amplifier 4 .. 20mA VA2		
10 kN 10K0		With IO-Link inline amplifier VAIO		
20 kN 20K0				
50 kN 50K0				

Ordering example

K-U9C-	05K0-	03M0-	VAIO-	S-	IO02
---------------	--------------	--------------	--------------	-----------	-------------

All cable lengths can be combined with all plugs.

TEDS can only be ordered in conjunction with a plug option. It is not possible to combine TEDS and free cable ends.

Versions with inline amplifiers (VA1, VA2 and VAIO) can only be combined with cable lengths 1.5 m and 3 m; TEDS is not available for these measurement chains.

All firmware versions only for sensors with IO-LINK interface.

ACCESSORIES

Accessories not included in the scope of supply.

Description	Ordering number
KAB168-5, PUR connection cable with M12 8-pin socket, 5 m long, opposite ends free. To connect the amplifier module to the downstream electronics. Not suitable for use with the IO-Link interface.	1-KAB168-5
KAB168-20, PUR connection cable with M12 8-pin socket, 20 m long, opposite ends free. To connect the amplifier module to the downstream electronics. Not suitable for use with the IO-Link interface.	1-KAB168-20
Ground cable 400 mm long	1-EEK4
Ground cable 600 mm long	1-EEK6
Ground cable 800 mm long	1-EEK8
Knuckle eye for nominal (rated) forces 50 N to 1 kN	1-Z8/100kg/ZGW
Knuckle eye for nominal (rated) forces 2 kN to 20 kN	1-U9/20kN/ZGWR
Knuckle eye for nominal (rated) force 50 kN	1-U9a/50kN/ZGW

Hottinger Brüel & Kjaer GmbH

Im Tiefen See 45 · 64293 Darmstadt · Germany
Tel. +49 6151 803-0 · Fax +49 6151 803-9100
www.hbkworld.com · info@hbkworl.com

Subject to modifications. All product descriptions are for general information only. They are not to be understood as a guarantee of quality or durability.