

DATA SHEET

U2B Force transducer

SPECIAL FEATURES

- Tensile/compressive force transducer
- Lateral force compensation
- Integrated lateral force compensation
- Nominal (rated) forces 500 N... 200 kN
- Non-rusting, degree of protection IP67
- Can be configured with different cable lengths, connector attachment, integrated amplifier (0 ... 10 V, 4 ... 20 mA or IO-Link) and TEDS on request
- Low height of construction



TABLE OF CONTENTS

Schematic diagram	2
Dimensions	3
U2B force transducer	3
U2B force transducer fitted with ZGOW and ZGUW knuckle eyes	4
U2B force transducer fitted with ZGOW knuckle eyes, without adapter	4
ZGOW and ZGUW mounting aids	5
Electrical connection	6
Connection with a fixed cable (without amplifier)	6
Connection with an M12 8-pin connector (with/without amplifier)	6
Connection with integrated VAIO amplifier with IO-Link	6
Specifications as per VDI/VDE 2638	7
Specifications without integrated amplifier	7
Specifications with integrated amplifier VA1 (0...10 V) and VA2 (4...20 mA)	9
Specifications with integrated VAIO amplifier	11
Versions and ordering numbers	13
Accessories	14

SCHEMATIC DIAGRAM

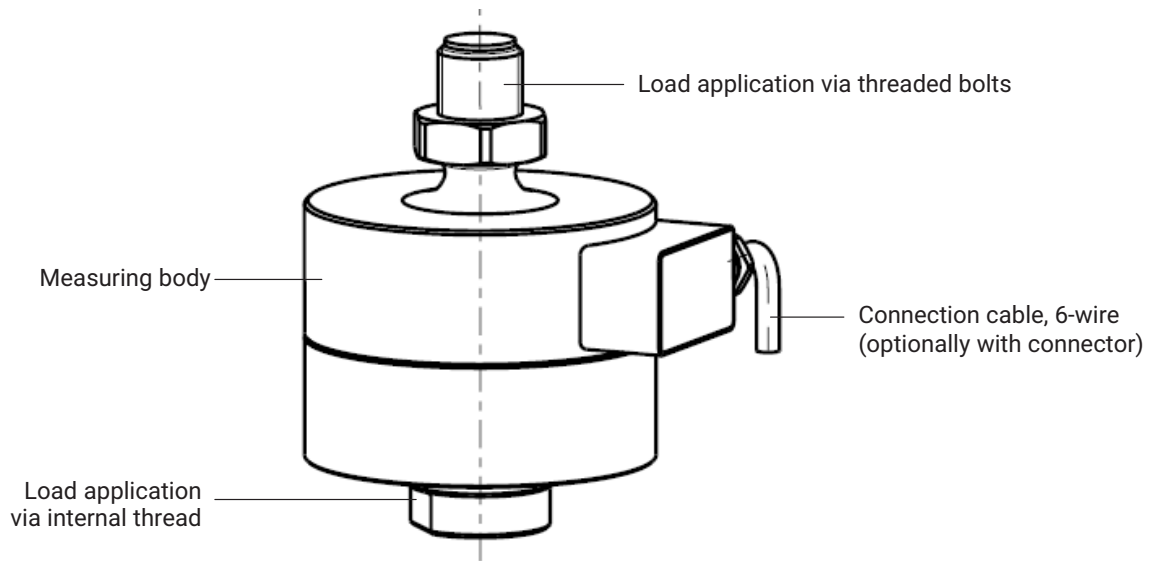

DIMENSIONS

U2B force transducer

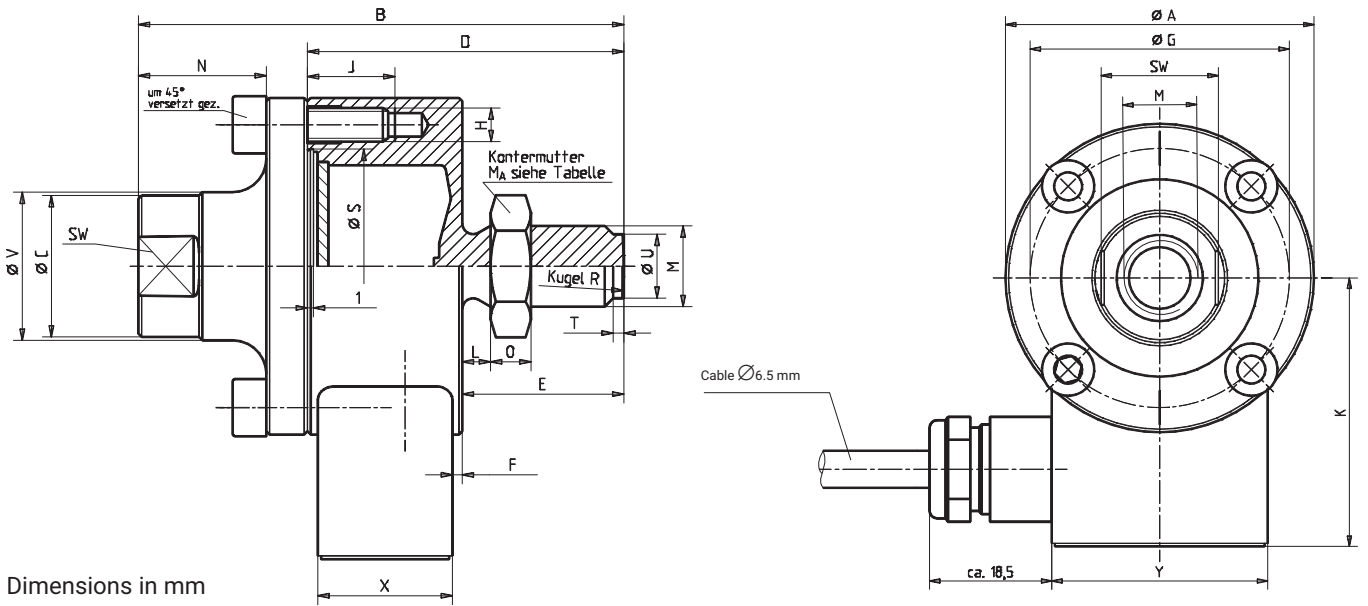

Dimensions in mm

Nominal (rated) force	$\varnothing A_{0.2}$	B	$\varnothing C$	D	E	F	$\varnothing G$	H	J	K	L	M	N	O	$\varnothing S_{f8}^{H8}$	a.f.	T	$\varnothing U$	$\varnothing V$	X	Y	M _A (N·m)	Ball R
0.5-5 kN	50	72	21	47	24	1.5	42	4xM5	13	43.5	4.2	M12	19	6	34	19	1.6	9.5	22	20	35	60	60
10 kN											7.6												
20 kN	90	112	33	72	38	2	70	4xM10	20.5	63.5	10.6	M20x1.5	15	10	55	30	2	17	34	30	50	300	100
50 kN	100	141	40	86	47	6	78	4xM12	19	68	13.2	M24x2	20	12	61	36	2	20	42			500	
100 kN	135	197	68	122	67	17	105	8xM12	16	85.5	19	M39x2	29	19	79	60	2	36	70	-	160		
200 kN	155	232	82	142	85	19	125	8xM16	26	95.5	24.2	M48x2	32	22	97	70	2.2	43	84	-			

Optionally passive or active with M12 A-coded connector

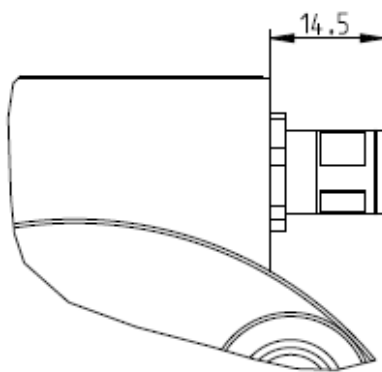

M12 male connector, A-coded, 8-pin

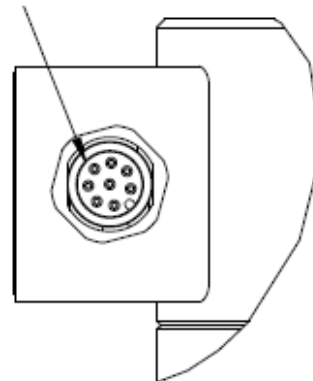

M12 male connector, A-coded, 4-pin

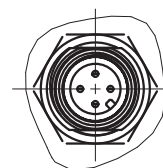

U2B force transducer fitted with ZGOW and ZGUW knuckle eyes

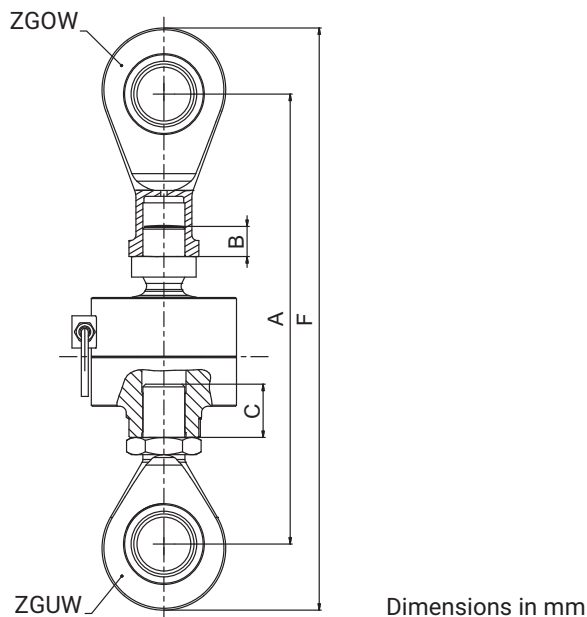

Nominal (rated) force [kN]	A_{min}	A_{max}	F_{min}	F_{max}	Minimum thread reach	
					b	c
0.5...10	139	156	171	188	9.6	9.6
20	212	234	262	284	16	16
50	260	288	320	348	19.2	19.2
100	418	436	541	559	27	31.2
200	466	489	602	625	36.6	38.4

U2B force transducer fitted with ZGOW knuckle eyes, without adapter

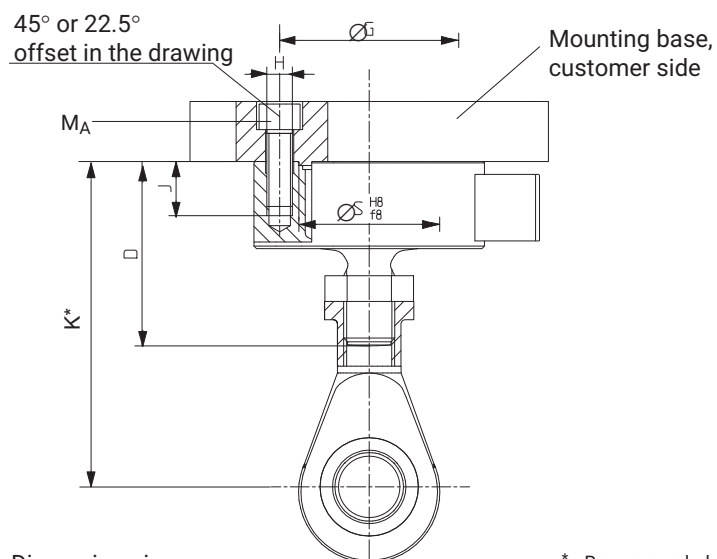

Dimensions in mm

* Recommended dimension, taking minimum thread reach into account

Nominal (rated) force in kN	D	$\varnothing S$	H	J	K	$\varnothing S$	MA ¹⁾ [N·m]
0.5...10	47	42	4xM5	13	84...86.4	34	5
20	72	70	4xM10	20.5	131.6	55	35
50	86	78	4xM12	19	158.2	61	60

Nominal (rated) force in kN	D	ØG	H	J	K	ØS	MA ¹⁾ [N·m]
100	122	105	8xM12	16	244	79	60
200	142	125	8xM16	26	270.2	97	150

1) Recommended values when using a torque wrench on dry thread

ZGOW and ZGUW mounting aids

Knuckle eye ZGOW

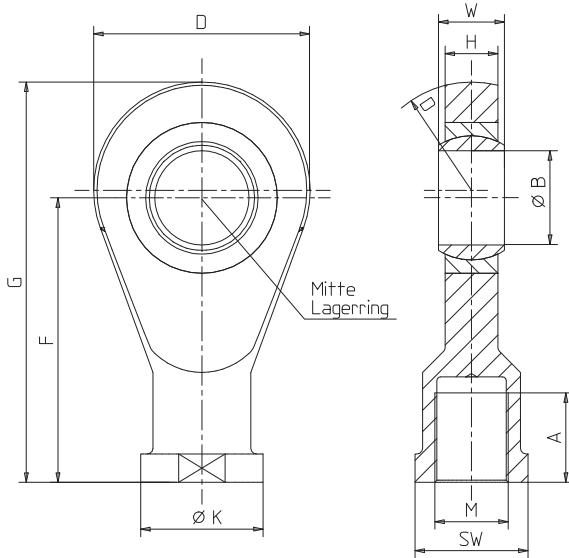

Knuckle eye ZGUW

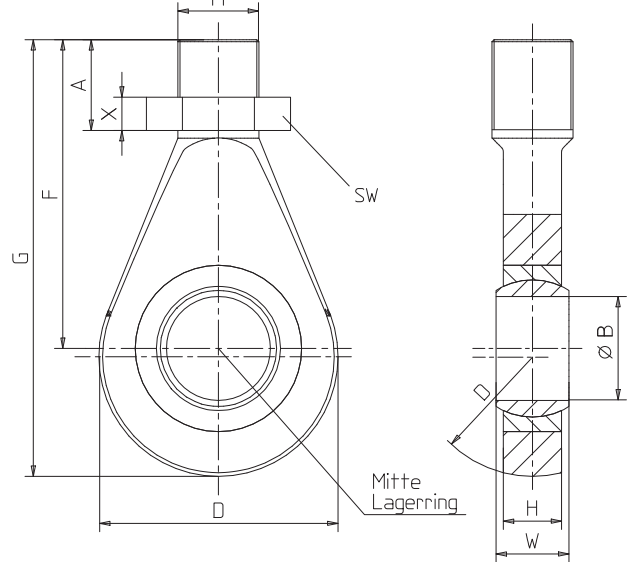

Material: Tempered steel, galvanized; roller bearing steel and PTFE/bronze corrugated foil
Dimensions in mm

Nominal (rated) force in kN	Ordering no. Knuckle eye ZGOW	Weight in kg	A	ØB	D	F	G	H	ØK	M	a.f.	W
0.5...10	1-U2A/1t/ZGOW	0.2	22	12 ^{H7}	32	50	66	12	22	M12	19	16
20	1-U2A/2t/ZGOW	0.5	33	20 ^{H7}	50	77	102	18	34	M20x1.5	32	25
50	1-U2A/5t/ZGOW	0.8	42	25 ^{H7}	60	94	124	22	42	M24x2	36	31
100	1-U2A/10t/ZGOW	3.2	50	50 ^{+0.002 -0.014}	115	151	212.5	28	65	M39x2	60	35
200	1-U2A/20t/ZGOW	4.8	60	60 ^{+0.003 -0.018}	126	167	235	36	82	M48x2	70	44

Nominal (rated) force in kN	Ordering no. Knuckle eye ZGUW	Weight in kg	A	ØB	D	F	G	H	M	a.f.	W	X
0.5...10	1-U2A/1t/ZGUW	0.1	33	12 ^{H7}	32	54	70	12	M12	19	16	7
20	1-U2A/2t/ZGUW	0.2	47	20 ^{H7}	50	78	103	18	M20x1.5	30	25	9
50	1-U2A/5t/ZGUW	0.4	57	25 ^{H7}	60	94	124	22	M24x2	36	31	10
100	1-U2A/10t/ZGUW	1.1	65.5	50 ^{+0.002 -0.014}	115	148.5	210	28	M39x2	60	35	16
200	1-U2A/20t/ZGUW	3.2	80	60 ^{+0.003 -0.018}	126	168	236	36	M48x2	75	44	18

ELECTRICAL CONNECTION

Connection with a fixed cable (without amplifier)

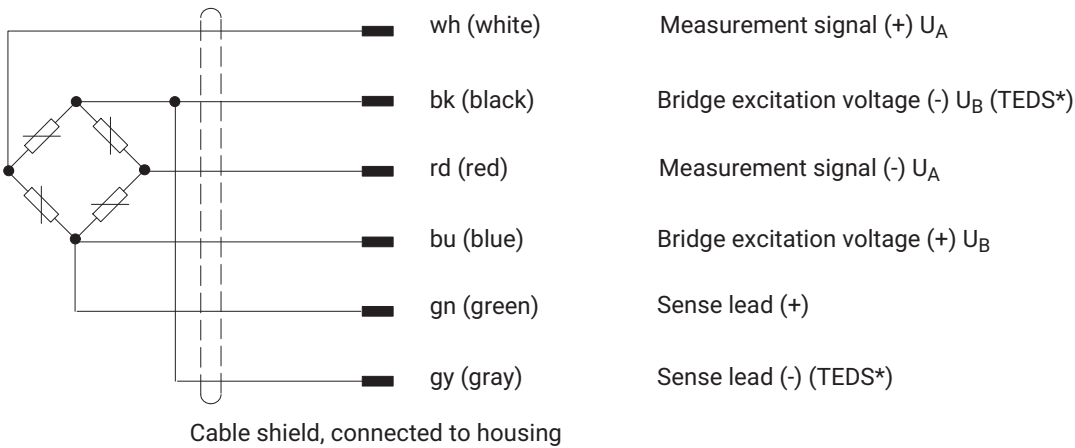

* only when option T is selected (transducer identification)

Connection with an M12 8-pin connector (with/without amplifier)

Pin	Wire color	Version VA 1 (voltage output)	Version VA 2 (current output)	Connection cable wire assignments without integrated amplifier
1	White	Supply voltage 0 V (GND)		Measurement signal (+)
2	Brown	Not in use		Bridge excitation voltage (-) (TEDS ¹⁾)
3	Green	Zeroing control input		Bridge excitation voltage (+)
4	Yellow	Not in use		Measurement signal (-)
5	Gray	Output signal 0 ... 10 V	Output signal 4 ... 20 mA	Not in use
6	Pink	Output signal 0 V	Not in use	Sense lead (+)
7	Blue	Not in use		Sense lead (-) (TEDS ¹⁾)
8	Red	Voltage supply +19 ... +30 V		Not in use

Cable shield, connected to housing

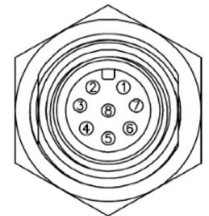

¹⁾ TEDS only if ordered

Connection with integrated VAIO amplifier with IO-Link

Pin	U2B assignment
1	Supply voltage +
2	Digital output (DI/DO pin function)
3	Supply voltage -, reference potential
4	IO-Link data (C/Q), switchover to the digital output (SIO mode) possible

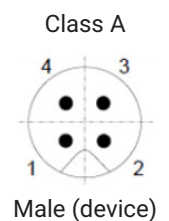

Specifications without integrated amplifier

Type			U2B without integrated amplifier								
Nominal (rated) force	F _{nom}	N	500								
		kN		1	2	5	10	20	50	100	200
Accuracy											
HBK accuracy class			0.2	0.1							
Relative reproducibility and repeatability errors in unchanged mounting position	b _{rg}	%	0.1								
Relative reversibility error (hysteresis) at 0.5 * F _{nom}	V _{0.5}	%	0.2	0.15							
Non-linearity	d _{lin}	%	0.2	0.1							
Relative zero point return	v _{w0}	%	0.05								
Relative creep over 30 min	d _{cr, F+E}	%	0.06								
Effect of the bending moment at 10% F _{nom} * 10mm	d _{Mb}	%	0.05								
Effect of lateral forces at 10% of F _{nom}	d _Q	%	0.1								
Temperature coefficient of sensitivity	TC _S	%/10K	0.1								
Temperature coefficient of zero signal	TC ₀	%/10K	0.1	0.05							
Rated electrical output											
Rated output (nominal)	C _{nom}	mV/V	2								
Relative zero signal error	d _{s,0}	%	1								
Characteristic curve deviation, tension	d _c	%	0.2								
Characteristic curve deviation, tension/compression	d _{zd}	%	1.5	0.5							
Input resistance	R _e	Ω	>345								
Output resistance	R _a	Ω	300 ... 400								
Insulation resistance	R _{iso}	GΩ	> 2								
Operating range of the excitation voltage	B _{U,G}	V	0.5 ... 12								
Reference excitation voltage	U _{ref}	V	5								
Connection			6-wire circuit								
Temperature											
Reference temperature	T _{ref}	°C [°F]	+23 [73.4]								
Nominal (rated) temperature range	B _{T,nom}	°C [°F]	-10 ... +70 [14 ... 158]								
Operating temperature range	B _{T,G}	°C [°F]	-30 ... +85 [-22 ... +185]								
Storage temperature range	B _{T,S}	°C [°F]	-50 ... +85 [-58 ... +185]								
Characteristic mechanical quantities											
Maximum operating force	F _G	% of F _{nom}	130	150							
Force limit	F _L		130	150							
Breaking force	F _B		> 300								
Torque limit	M _{G max}	Nm	46.5	63	63	60	108	340	620	2430	5125
Bending moment limit	M _{b max}		2.9	12.8	19	24	49	223	380	1463	2880

Type			U2B without integrated amplifier								
Nominal (rated) force	F _{nom}	N	500								
		kN		1	2	5	10	20	50	100	200
Static lateral force limit	F _Q	% of F _{nom}	25	52	36	18	25	35	19	25	19
Nominal (rated) displacement	s _{nom}	mm	0.058	0.056	0.048	0.047	0.047	0.065	0.082	0.09	0.12
Natural frequency	f _G	kHz	4	6	8.7	14	17.5	8	8.5	6	5.6
Permissible oscillation stress	f _{rb}	% of F _{nom}	100	160							
Stiffness	c _{ax}	10 ⁵ N/mm	0.08 6	0.18	0.42	1.06	2.13	3.08	6.1	11.1	16.67
General information											
Degree of protection in accordance with EN 60529			IP67 ¹⁾								
Spring element material			Stainless steel								
Measuring point protection			Hermetically-welded measuring body								
Cable (only with "fixed cable" option)			6-wire, polyethylene insulated								
Cable length (standard version)		m	3			6			12		
Cable length (to customer requirements)			See "U2B versions and ordering numbers"								
Weight	m	kg	0.8			2.9	4.3	10.7	15.9		
	m	lbs	1.76			6.4	9.48	23.6	35.05		
Mechanical shock resistance as per IEC 60068-2-6											
Number		n	1000								
Duration		ms	3								
Acceleration		m/s ²	637								
Vibrational stress as per IEC 60068-2-27											
Frequency range		Hz	5 ... 65								
Duration		min	30								
Acceleration		m/s ²	150								

1) Test condition: 1 m water column, 0.5 hours; connected with cable if version with M12 male connector selected

Specifications with integrated amplifier VA1 (0...10 V) and VA2 (4...20 mA)

Type			U2B with integrated VA1 and VA2 amplifier								
Nominal (rated) force	F _{nom}	N	500								
		kN		1	2	5	10	20	50	100	200
Accuracy											
HBK accuracy class			0.2	0.1							
Relative reproducibility and repeatability errors in unchanged mounting position	b _{rg}	%	0.1								
Relative reversibility error (hysteresis) at 0.5 * F _{nom}	V _{0,5}	%	0.2	0.15							
Non-linearity	d _{lin}	%	0.2	0.1							
Relative zero point return	V _{w0}	%	0.05								
Relative creep over 30 min	d _{cr, F+E}	%	0.06								
Effect of the bending moment at 10% F _{nom} * 10 mm	d _{Mb}	%	0.05								
Effect of lateral forces at 10% of F _{nom}	d _Q	%	0.1								
Temperature coefficient of sensitivity	TC _S	%/10K	0.1								
Temperature coefficient of zero signal	TC ₀	%/10K	0.1	0.05							
Rated electrical output VA1 (voltage output)											
Output signal		V	0 ... 10								
Rated output (nominal)		V	5								
Sensitivity tolerance		V	±0.1								
Zero signal		V	5								
Rated output variation for tension/pressure	d _{zd}	%	1.5	0.05							
Output signal range		V	-0.3 ... 11								
Cut-off frequency (-3 db)	f _G	kHz	2								
Nominal (rated) supply voltage	U _{ref}	V	24								
Operating range of the supply voltage	B _{u,gt}	V	19 ... 30								
Max. current consumption		mA	15								
Electrical connection			M12 connector, 8-pin, A-coded								
Rated electrical output VA2 (voltage output)											
Output signal		mA	4 ... 20								
Rated output (nominal)		mA	8								
Sensitivity tolerance		mA	±0.16								
Zero signal		mA	12								
Rated output variation for tension/pressure	d _{zd}	%	1.5	0.05							
Output signal range		mA	3 ... 21								
Cut-off frequency (-3 db)	f _G	kHz	2								
Nominal (rated) supply voltage	U _{ref}	V	24								
Operating range of the supply voltage	B _{u,gt}	V	19 ... 30								
Max. current consumption		mA	30								
Electrical connection			M12 connector, 8-pin, A-coded								

Type			U2B with integrated VA1 and VA2 amplifier								
Nominal (rated) force	F _{nom}	N	500								
		kN		1	2	5	10	20	50	100	200
Temperature											
Reference temperature	T _{ref}	°C [°F]	+23 [73.4]								
Nominal (rated) temperature range	B _{T, nom}	°C [°F]	-10 ... +50 [14 ... 122]								
Operating temperature range	B _{T, G}	°C [°F]	-20 ... +60 [-4 ... +140]								
Storage temperature range	B _{T, S}	°C [°F]	-25 ... +85 [-77 ... +185]								
Characteristic mechanical quantities											
Maximum operating force	F _G	% of F _{nom}	130	150							
Force limit	F _L		130	150							
Breaking force	F _B		> 300								
Torque limit	M _{G max}	Nm	46.5	63	63	60	108	340	620	2430	5125
Bending moment limit	M _{b max}		2.9	12.8	19	24	49	223	380	1463	2880
Static lateral force limit	F _q	% of F _{nom}	25	52	36	18	25	35	19	25	19
Nominal (rated) displacement	s _{nom}	mm	0.058	0.056	0.048	0.047	0.047	0.065	0.082	0.09	0.12
Natural frequency	f _G	kHz	4	6	8.7	14	17.5	8	8.5	6	5.6
Permissible oscillation stress	f _{rb}	% of F _{nom}	100	160							
Stiffness	c _{ax}	10 ⁵ N/mm	0.086	0.18	0.42	1.06	2.13	3.08	6.1	11.1	16.67
General information											
Degree of protection in accordance with EN 60529			IP67 ²⁾								
Spring element material			Stainless steel								
Material of permanently installed amplifier housing			Stainless steel								
Measuring point protection			Hermetically-welded measuring body								
Weight	m	kg	0.8				2.9	4.3	10.7	15.9	
	m	lbs	1.76				6.4	9.48	23.6	35.05	
Mechanical shock resistance as per IEC 60068-2-6											
Number		n	1000								
Duration		ms	3								
Acceleration		m/s ²	637								
Vibrational stress as per IEC 60068-2-27											
Frequency range		Hz	5 ... 65								
Duration		min	30								
Acceleration		m/s ²	150								

2) Test condition: 1 m water column, 0.5 hours; connected with cable if version with M12 male connector selected

Specifications with integrated VAIO amplifier

Type			U2B with integrated VAIO amplifier								
Nominal (rated) force	F_{nom}	N	500								
		kN		1	2	5	10	20	50	100	200
Accuracy											
HBK accuracy class			0.2	0.1							
Relative reproducibility and repeatability errors in unchanged mounting position	b_{rg}	%	0.1								
Relative reversibility error (hysteresis) at $0.5 \cdot F_{nom}$	$V_{0.5}$	%	0.2	0.15							
Non-linearity	d_{lin}	%	0.03								
Relative zero point return	V_{w0}	%	0.05								
Relative creep over 30 min	$d_{cr, F+E}$	%	0.06								
Effect of the bending moment at $10\% F_{nom} \cdot 10 \text{ mm}$	d_{Mb}	%	0.05								
Effect of lateral forces at 10% of F_{nom}	d_Q	%	0.1								
Temperature coefficient of sensitivity	TC_S	%/10K	0.1								
Temperature coefficient of zero signal	TC_0	%/10K	0.03								
VAIO electrical characteristics											
Output signal, interface			COM3, to IO-Link standard, class A								
Min. cycle time		ms	0.9								
Sample rate (internal)		S/s	40000								
Cut-off frequency (-3 db)	f_G	kHz	4								
Nominal (rated) supply voltage	U_{ref}	V	24								
Operating range of the supply voltage	$B_{u,gt}$	V	19 ... 30								
Maximum power consumption		mW	3200								
Noise		ppm of nominal force	With Bessel filter 1Hz: 25 With Bessel filter 10 Hz: 63 With Bessel filter 100 Hz: 195 With Bessel filter 200 Hz: 275 Without filter: 3020								
Low-pass filter			Freely adjustable cut-off frequency, Bessel or Butterworth characteristic, 6th order								
Variation in relative characteristic value for tension/pressure	d_{zd}	%	0.03								
Device functions											
Limit value switches	2 limit value switches. Invertible, freely adjustable hysteresis. Output via process data or digital output										
Digital I/O	According to IO-Link Smart Sensor Profile, 1 permanently available digital output; 1 output can be set to data output. Measurement is then not possible										
Slave pointer function	Yes										
Peak value memory	Yes										
Peak-to-peak memory	Yes										
Warning functions	Warning on exceeding nominal (rated) force/maximum operating force; Nominal (rated) temperature/maximum operating force										
Temperature											
Reference temperature	T_{ref}	°C [°F]	+23 [73.4]								

Type			U2B with integrated VAIO amplifier								
Nominal (rated) force	F _{nom}	N	500								
		kN		1	2	5	10	20	50	100	200
Nominal (rated) temperature range	B _{T, nom}	°C [°F]	-10 ... +50 [14 ... 122]								
Operating temperature range	B _{T, G}	°C [°F]	-10 ... +60 [14 ... +140]								
Storage temperature range	B _{T, S}	°C [°F]	-25 ... +85 [-77 ... +185]								
Characteristic mechanical quantities											
Maximum operating force	F _G	% of F _{nom}	130	150							
Force limit	F _L		130	150							
Breaking force	F _B		> 300								
Torque limit	M _{G max}	Nm	46.5	63	63	60	108	340	620	2430	5125
Bending moment limit	M _{b max}		2.9	12.8	19	24	49	223	380	1463	2880
Static lateral force limit	F _q	% of F _{nom}	25	52	36	18	25	35	19	25	19
Nominal (rated) displacement	s _{nom}	mm	0.058	0.056	0.048	0.047	0.047	0.065	0.082	0.09	0.12
Natural frequency	f _G	kHz	4	6	8.7	14	17.5	8	8.5	6	5.6
Permissible oscillation stress	f _{rb}	% of F _{nom}	100	160							
Stiffness	c _{ax}	10 ⁵ N/mm	0.086	0.18	0.42	1.06	2.13	3.08	6.1	11.1	16.67
General information											
Degree of protection in accordance with EN 60529			IP67 ³⁾								
Spring element material			Stainless steel								
Material of permanently installed amplifier housing			Stainless steel								
Measuring point protection			Hermetically-welded measuring body								
Weight	m	kg	0.8				2.9	4.3	10.7	15.9	
	m	lbs	1.76				6.4	9.48	23.6	35.05	
Mechanical shock resistance as per IEC 60068-2-6											
Number		n	1000								
Duration		ms	3								
Acceleration		m/s ²	637								
Vibrational stress as per IEC 60068-2-27											
Frequency range		Hz	5 ... 65								
Duration		min	30								
Acceleration		m/s ²	150								

³⁾ Test condition: 1 m water column, 0.5 hours; connected with cable if version with M12 male connector selected

VERSIONS AND ORDERING NUMBERS

Measuring range	Ordering number	<p>The ordering numbers shown in gray are preferred types and can be delivered rapidly. All preferred types with a cable length of 3/6/12 m (depending on the nominal (rated) force) with free ends, without TEDS, without integrated amplifier and, consequently, without firmware.</p> <p>The ordering number for customer-specific designs is K-U2B-...</p> <p>The ordering number example K-U2B--020K-00A4-X-S-VAIO-IO03 shown below is at U2B, nominal (rated) force 20 kN, no fixed cable on the sensor, no TEDS and with integrated amplifier (IO-Link output).⁴</p>
500 N	1-U2B/500N	
1 kN	1-U2B/1KN	
2 kN	1-U2B/2KN	
5 kN	1-U2B/5KN	
10 kN	1-U2B/10KN	
20 kN	1-U2B/20KN	
50 kN	1-U2B/50KN	
100 kN	1-U2B/100KN	
200 kN	1-U2B/200KN	

Nominal (rated) force	Electrical connection ¹⁾	Plug version for the "fixed mounted cable" option	Transducer identification	Integrated amplifier	Firmware
500 N 500N	4-pin M12 male connector, A-coded 00A4	Free ends Y	With TEDS ²⁾ T	No amplifier N	No firmware N
1 kN 001K	8-pin M12 male connector, A-coded 00A8	D-SUB, 15-pin F	Without TEDS S	Amplifier 0 ... 10 V VA1	Version 2.0.10 ³⁾ IO04
2 kN 002K	Fixed cable (1 m) 01M0	D-SUB-HD15, 15-pin Q		Amplifier 4 ... 20 mA VA2	Version 2.0.12 ³⁾ IO05
5 kN 005K	Fixed cable (3 m) 03M0	Male connector MS3106PEMV N		Digital amplifier: IO-Link VAIO	
10 kN 010K	Fixed cable (6 m) 06M0	CON P1016 male connector P			
20 kN 020K	Fixed cable (12 m) 12M0	M12 connector, 8-pin M			
50 kN 050K	Fixed cable (20 m) 20M0	No cable available X			
100 kN 100K					
200 kN 200K					

K-U2B--	020K-	00A4-	X-	S-	VAIO-	IO04
----------------	--------------	--------------	-----------	-----------	--------------	-------------

¹⁾ M12 8-Pin male connectors or fixed cables can be ordered for passive sensors. M12 4-pin male connectors (IO-Link output) and M12 8-pin male connectors (current and voltage output) are available for active sensors.

²⁾ TEDS only for sensors without amplifier module

³⁾ Only for versions with IO-Link interface

ACCESSORIES

The accessories are not included in the scope of supply.

Description	Ordering number
Ground cable, 400 mm	1-EEK4
Ground cable, 600 mm	1-EEK6
Ground cable, 800 mm	1-EEK8
Knuckle eye with internal thread. Force range 500 N to 10 kN	1-U2A/1t/ZGOW
Knuckle eye with internal thread. Force range 20 kN	1-U2A/2t/ZGOW
Knuckle eye with internal thread. Force range 50 kN	1-U2A/5t/ZGOW
Knuckle eye with internal thread. Force range 100 kN	1-U2A/10t/ZGOW
Knuckle eye with internal thread. Force range 200 kN	1-U2A/20t/ZGOW
Knuckle eye with external thread. Force range 500 N to 10 kN	1-U2A/1t/ZGUW
Knuckle eye with external thread. Force range 20 kN	1-U2A/2t/ZGUW
Knuckle eye with external thread. Force range 50 kN	1-U2A/5t/ZGUW
Knuckle eye with external thread. Force range 100 kN	1-U2A/10t/ZGUW
Knuckle eye with external thread. Force range 200 kN	1-U2A/20t/ZGUW
Cable to connect to M12 male connector, 5 m long; not suitable for the IO-Link interface	1-KAB168-5
Cable to connect to M12 male connector, 20 m long; not suitable for the IO-Link interface	1-KAB168-20

Hottinger Brüel & Kjaer GmbH

Im Tiefen See 45 · 64293 Darmstadt · Germany
Tel. +49 6151 803-0 · Fax +49 6151 803-9100
www.hbkworld.com · info@hbkworld.com

Subject to modifications. All product descriptions are for general information only.
They are not to be understood as a guarantee of quality or durability.