

DATA SHEET

Z4A

Force transducers

SPECIAL FEATURES

- Highest accuracy tensile/compressive force transducers
- Nominal (rated) forces 20 kN... 500 kN
- Meets the requirements of class 00 in accordance with ISO 376
- Suitable as transfer standard in international force comparison
- Excellent long-term stability



TABLE OF CONTENTS

Dimensions Z4A	2
Electrical connection	2
Specifications	3
Ordering number	4
Accessories	5
Force application parts for standard measurements in industry	5
Force application parts for precision measurements	6

DIMENSIONS Z4A

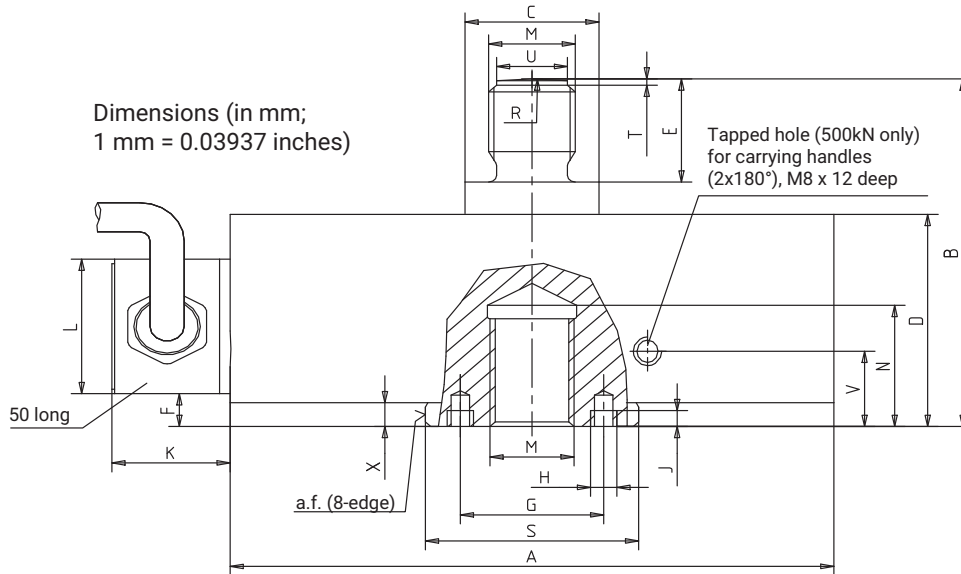

Type/ Ordering no.	Ø A	B	Ø C	D	E	F	G	H	J	K	L	M	N	R	Ø S	T	Ø U	V	X	a.f.
1-Z4A/20kN	115±3	77.5	25.5	47.3	23	7.3	-	-	-	22	30	M16	27	60	40.5	1.4	13.5	-	5.3	38
1-Z4A/50kN	120±3	83.4	26.5	55.2	23	10.2	-	-	-	22	30	M20x1.5	28	60	48.6	1.4	17.5	-	8.2	45
1-Z4A/100kN	146±3	107.4	40.5	69.2	33	12.2	-	-	-	22	30	M30x2	37	160	62.6	1.4	27.5	-	10.2	59
1-Z4A/200kN	180±3	137.3	50.5	89.1	43	13.1	68	M6	6	22	30	M39x2	45	160	76.3	1.8	36.5	-	11.1	73
1-Z4A/500kN	275±3	250	100.5	145	95	21	118	M8	8	32	43	M72x4	87	400	140	3	65.5	55	20	134

ELECTRICAL CONNECTION

6-wire connection



Cable shield, connected to the housing

SPECIFICATIONS

Type	Z4A						
Nominal (rated) force	F_{nom}	kN	20	50	100	200	500
Accuracy values per ISO 376							
Accuracy class in force measurement range 20...100% of F_{nom}			00				
Repeatability (20...100% of F_{nom}) in one mounting position	b`	%	0.02				
Reproducibility (20...100% of F_{nom}) in various mounting positions	b`	%	0.02				0.03
Deviation from the fitting curve (20...100% of F_{nom})	f_c	%	0.02				
Zero error	f_o	%	0.008				
Reverse span (20...100% of F_{nom})	v	%	0.06				0.07
Creep	c	%	0.02				
Accuracy							
HBK accuracy class			0.02				0.03
Relative reproducibility and repeatability errors in unchanged mounting position	b_{rg}	%	0.02				
Relative reversibility error (hysteresis) at 0.4 F_{nom}	$v_{0.4}$	%	0.02				
Non-linearity	d_{lin}	%	0.02				0.03
Relative zero point return	d_0	%	0.008				
Relative creep	d_{crF+E}	%	0.02				
Effect of lateral forces (lateral force 10 % F_{nom})	d_Q	%	0.03				
Temperature coefficient of sensitivity	TC_S	%/10 K	0.01				
Effect of temperature on zero signal	TC_0	%/10 K	0.015				
Rated electrical output							
Nominal (rated) output	C_{nom}	mV/V	2				
Rated output error	d_c	%	0.1				
Relative zero signal error	$d_{s,o}$	%	0.5				
Rated output variation for tension/compression	d_{zd}	%	0.2				
Input resistance	R_e	Ω	>345				
Output resistance	R_a	Ω	356 \pm 0.3				
Insulation resistance	R_{is}	G Ω	>5				
Operating range of the excitation voltage	$B_{U,G}$	V	0.5...12				
Reference excitation voltage	U_{ref}	V	5				
Connection			6-wire circuit				
Temperature							
Reference temperature	T_{ref}	$^{\circ}C$ [$^{\circ}F$]	+23 [+73.4]				
Nominal (rated) temperature range	$B_{T,nom}$	$^{\circ}C$ [$^{\circ}F$]	+10...+40 [+50...+104]				
Operating temperature range	$B_{T,G}$	$^{\circ}C$ [$^{\circ}F$]	-30...+85 [-22...+185]				
Storage temperature range	$B_{T,S}$	$^{\circ}C$ [$^{\circ}F$]	-50...+85 [-58...+185]				
Characteristic mechanical quantities							
Maximum operating force	F_G	% of F_{nom}	150				
Force limit	F_L		150				
Breaking force	F_B		250				
Torque limit	$M_{G,max}$	N·m	120	350	950	2000	4000
Static lateral force limit	F_q	% of F_{nom}	30				
Nominal (rated) displacement	s_{nom}	mm	0.2		0.25	0.28	0.45
Natural frequency	f_G	kHz	4.1	4.5	3.4	3.6	2.5
Permissible oscillation stress	f_{rb}	% of F_{nom}	70				50

Nominal (rated) force	F_{nom}	kN	20	50	100	200	500
Stiffness	C_{ax}	10 ⁵ N/mm	1	3	4	7	11
General information							
Degree of protection per EN 60529			IP67				
Spring element material			Steel				
Measuring point protection			Firmly glued sensor				
Mechanical shock resistance as per IEC 60068-2-27							
Number		n	1,000				
Duration		ms	3				
Acceleration		m/s ²	1,000				
Vibrational stress as per IEC 60068-2-6							
Frequency range		Hz	5..65				
Duration		min	30				
Acceleration		m/s ²	150				
Weight	m	kg	1.8	2.4	5.5	11.2	42
		lbs	4	5.3	12.1	24.7	92.6
Cable length		m	6				

ORDERING NUMBER

Ordering code	Nominal (rated) force					Unit
1-Z4A/...	20	50	100	200	500	kN

Ordering example: 1-Z4A/50kN

ACCESSORIES

Accessories (not included in the scope of supply)	Ordering number
Ground cable 400 mm long	1-EEK4
Ground cable 600 mm long	1-EEK6
Ground cable 800 mm long	1-EEK8
Knuckle eye, M16 external thread	1-Z4/20kN/ZGUW
Knuckle eye, M20 x 1.5 external thread	1-U2A/2t/ZGUW
Knuckle eye, M30 x 2 external thread	1-Z4/100kN/ZGUW
Knuckle eye, M39 x 2 external thread	1-U2A/10t/ZGUW
Knuckle eye, M72 x 4 external thread	1-Z4/500kN/ZGUW
Knuckle eye, M16 internal thread	1-Z4/20kN/ZGOW
Knuckle eye, M20 x 1.5 internal thread	1-U2A/2t/ZGOW
Knuckle eye, M30 x2 internal thread	1-Z4/100kN/ZGOW
Knuckle eye, M39 x2 internal thread	1-U2A/10t/ZGOW
Knuckle eye, M72 x 4 internal thread	1-Z4/500kN/ZGOW
Tensile force application to ISO376, suitable for Z4A with nominal (rated) force 20 kN	1-Z4/20kN/ZKM
Tensile force application to ISO376, suitable for Z4A with nominal (rated) force 50 kN	1-Z4A/50kN/ZKM
Tensile force application to ISO376, suitable for Z4A with nominal (rated) force 100 kN	1-Z4A/100kN/ZKM
Tensile force application to ISO376, suitable for Z4A with nominal (rated) force 200 kN	1-Z4A/200kN/ZKM
Tensile force application to ISO376, suitable for Z4A with nominal (rated) force 500 kN	1-Z4A/500kN/ZKM
Thrust piece to ISO376, suitable for Z4A with nominal (rated) force 20 kN	1-EDO4/20kN
Thrust piece to ISO376, suitable for Z4A with nominal (rated) force 50 kN	1-EDO4/50kN
Thrust piece to ISO376, suitable for Z4A with nominal (rated) force 100 kN	1-EDO4/100kN
Thrust piece to ISO376, suitable for Z4A with nominal (rated) force 200 kN	1-EDO4/200kN
Thrust piece to ISO376, suitable for Z4A with nominal (rated) force 500 kN	1-EDO4/500kN

Force application parts for standard measurements in industry

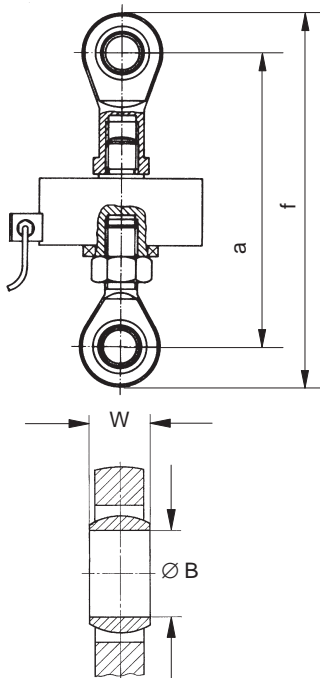

Knuckle eyes ZGOW/ZGUW

Dimensions in mm

Type	Knuckle eye top Knuckle eye bottom Ordering no.	Weight (kg)	a		f		W	Ø B
			min	max	min	max		
Z4A/20 kN	1-Z4/20kN/ZGOW 1-Z4/20kN/ZGUW	0.2	approx. 158	approx. 170	approx. 198	approx. 210	21	16 ^{H7}
Z4A/50 kN	1-U2A/2t/ZGOW 1-U2A/2t/ZGUW	0.8. 0.4	approx. 190	approx. 199	approx. 245	approx. 254	25	20 ^{H7}
Z4A/100 kN	1-Z4/100kN/ZGOW 1-Z4/100kN/ZGUW	1.1	approx. 261	approx. 269	approx. 331	approx. 339	37	30 ^{H7}
Z4A/200 kN	1-U2A/10t/ZGOW 1-U2A/10t/ZGUW	3.2. 1.1	approx. 352	approx. 357	approx. 475	approx. 480	35	50 ^{+0.001} _{-0.014}
Z4A/500 kN	1-Z4/500kN/ZGOW 1-Z4/500kN/ZGUW	17.3. 12.0	approx. 570	approx. 590	approx. 764	approx. 784	44	60 ^{+0.003} _{-0.018}

1) Secured against torsion by 2 screws; transducer side with internal thread

Force application parts for precision measurements

According to DIN EN10002-3 or ISO 376

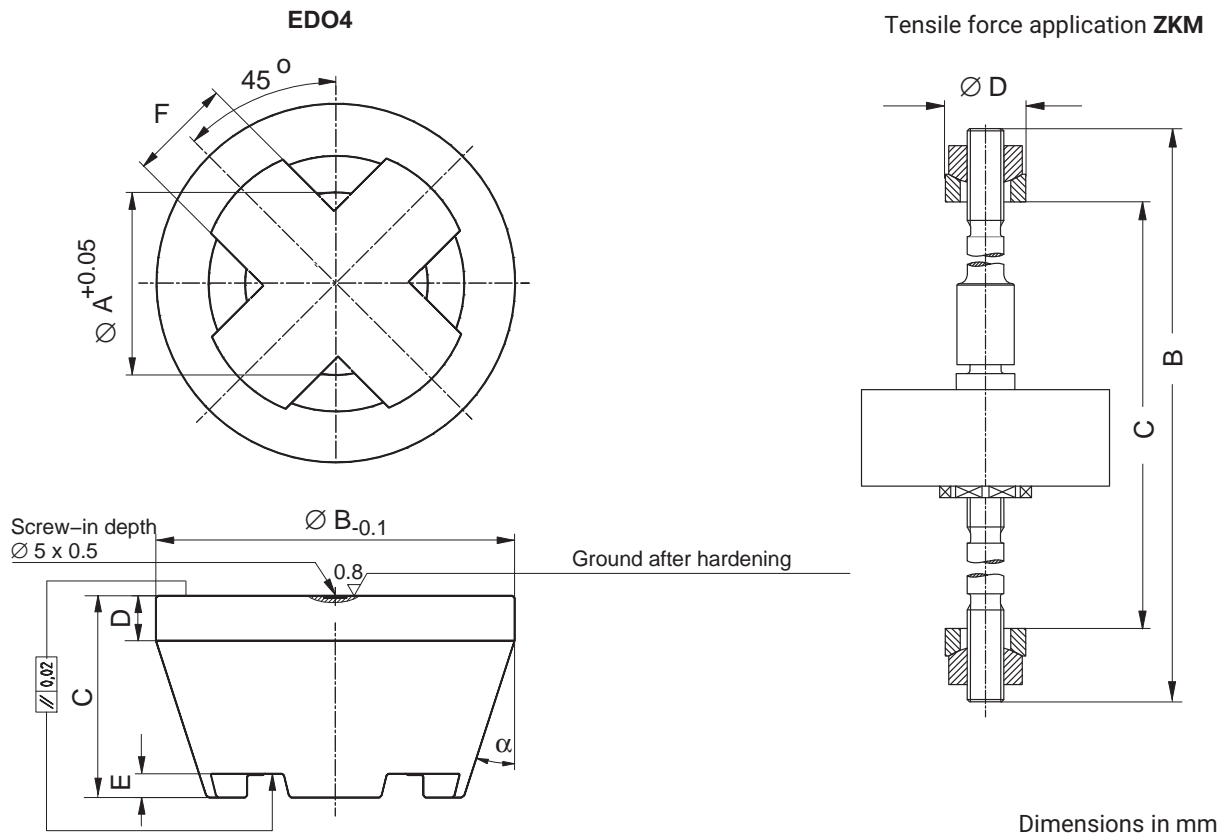

Type	Thrust piece Ordering no.	Weight (kg)	Ø A	Ø B	C	D	E	F	α
Z4A/20kN	1-EDO4/20kN	0.34	16.2	48	29	8	5	8	18
Z4A/50kN	1-EDO4/50kN		20.2					12	
Z4A/100kN	1-EDO4/100kN	1.58	30.2	80	45	10	18		
Z4A/200kN	1-EDO4/200kN		39.2				23		
Z4A/500kN	1-EDO4/500kN	4.35	72.4	112	68	15	12	30	15

Type	ZKM Ordering no.	Weight (kg)	B	C		ØD
				min.	max.	
Z4A/20kN	1-Z4/20kN/ZKM	0.82	325	228	276	35 ^{+0.120} _{-0.280}
Z4A/50kN	1-Z4/50kN/ZKM	1.45	350	248	299	45 ^{+0.130} _{-0.290}
Z4A/100kN	1-Z4/100kN/ZKM	2.32	395	277	334	50 ^{+0.130} _{-0.290}
Z4A/200kN	1-Z4/200kN/ZKM	4.19	447	317	382	64 ^{+0.140} _{-0.330}
Z4A/500kN	1-Z4/500kN/ZKM	20.1	623	432	522	90 ^{+0.170} _{-0.390}

Hottinger Brüel & Kjaer GmbH

Im Tiefen See 45 · 64293 Darmstadt · Germany
 Tel. +49 6151 803-0 · Fax +49 6151 803-9100
 www.hbkworld.com · info@hbkworl.com

Subject to modifications. All product descriptions are for general information only. They are not to be understood as a guarantee of quality or durability.